

WAGNER MODEL L722
"STACK PROBE"
ATTACHMENT

OWNER'S MANUAL

DOCUMENT No: [500-72203-001](#)
REV: E

Copyright Notice

Wagner Model L722 “Stack Probe” Attachment Owner’s Manual

© Copyright 2001-2003 Wagner Electronic Products, Inc. All Rights Reserved Worldwide. No part of this publication may be reproduced, transmitted, transcribed, stored in a retrieval system, or translated into any other language in any form by any means without the express written permission of Wagner Electronic Products, Inc.

Table of Contents

L722 STACK PROBE ATTACHMENT	3
L722 SPECIFICATIONS	3
L722 CALIBRATION	3
L722 MAINTENANCE	4
L722 OPERATION	6
MAINTAINING ACCURACY OF MOISTURE CONTENT READINGS.....	6
REPAIR SERVICE	9
REPLACEMENT PARTS	10
COIL CORD REPLACEMENT	11
WARRANTY	14
WARNINGS	15

L722 STACK PROBE ATTACHMENT

The Model L722 Stack Probe attachment, coupled with the L612 Digital Recording Moisture Meter makes it easy to reach deep into stickered units of lumber and take accurate moisture readings without the danger of broken pins. Wagner's "Wood-Friendly" electromagnetic wave technology makes it possible to take multiple readings throughout an entire stack in just minutes.

Once the probe is inserted between the boards, the springs press the end-mounted sensor flat against the wood and ensure deep penetration of the electro-magnetic field. You then slide the probe slowly out of the stack, reading the moisture in each board as the sensor passes over it. Virtually unaffected by surface moisture, the L722 gives consistent and reliable readings in or out of kilns.

Patents 5,488,312
5,486,815
5,402,076

L722 SPECIFICATIONS

Overall Size Incl. Handle: L722L - L 48in x W 6.0in x H 1.625 in (121.9cm x 15.2cm x 4.12cm)
L722s - L34in x W 6.0in x H 1.625 in (86.3cm x 15.2cm x 4.12cm)
Probe Reach: L722L - L 40.5in (102.8cm)
L722s - L 26.75in (67.9cm)
Extrusion and Sensor Head: 0.5in (12.7mm) thickness
Min/Max Sticker Range: 0.5in –0.9in (12.7mm – 22.9mm)
Scanning Area: 2.5in x 2.5in (6.35cm x 6.35cm)
Scanning Depth: 1.0in (2.54cm) minimum
Shipping Weight: L722L - 128 oz. (3.64kg)
L722s - 112 oz. (3.18kg)

L722 CALIBRATION

Calibration is factory set. Calibration may be checked by using the Calibration Verification Block (included with the L612), and following the instructions in the L612 Manual. The probe calibration is verified in the same manner as the L612 (Refer to the L612 Owner's Manual).

L722 MAINTENANCE

CLEANING

Maintenance of the probe consists of cleaning the probe assembly periodically with mild detergent cleaning solution and a soft rag. Do not soak or submerge the probe in liquid. Scrape excess pitch off with a flat bladed instrument such as a chisel or putty knife, being careful not to dig into the probe. Never use solvent of any kind for cleaning.

SPRING REPLACEMENT

When cleaning under the springs, remove the springs. **NEVER** lift up on the springs this will distort the metal. If the springs should become damaged in any way replace them in pairs. Replacement springs are included in the L722 Parts Kit (#880-72202-001), which may be purchased from the factory or through your distributor.

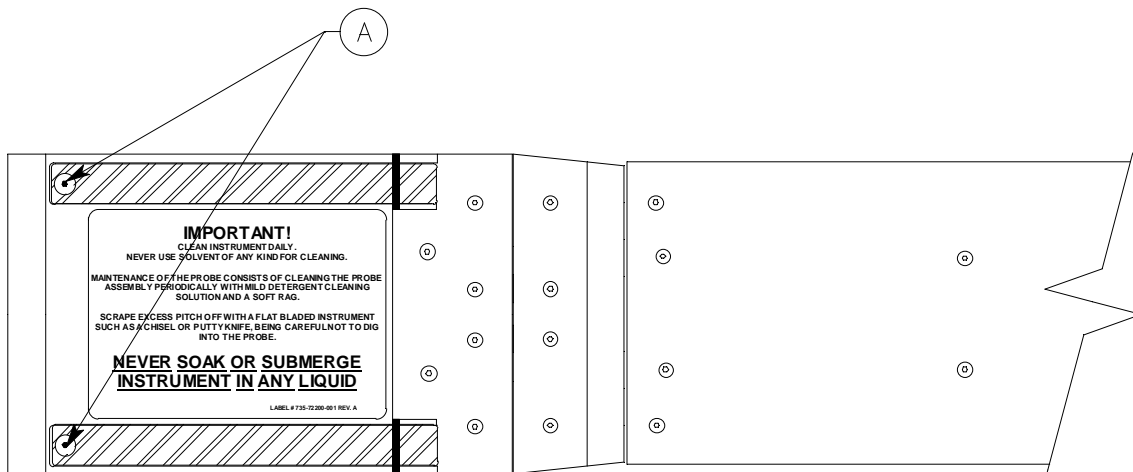

Symbol	Description
A	REMOVE HEX SOCKET CAP SCREWS. REPLACE SPRINGS.

HINGE REPAIR/REPLACEMENT

If the hinge becomes stretched, removal of the hinge screws and reseating of the hinge is all that is normally necessary. (Waiting for 30 minutes with the hinge removed will allow the hinge material to relax). If the hinge is severely distorted, a replacement can be obtained by purchasing the L722 Parts Kit (#880-72202-001).

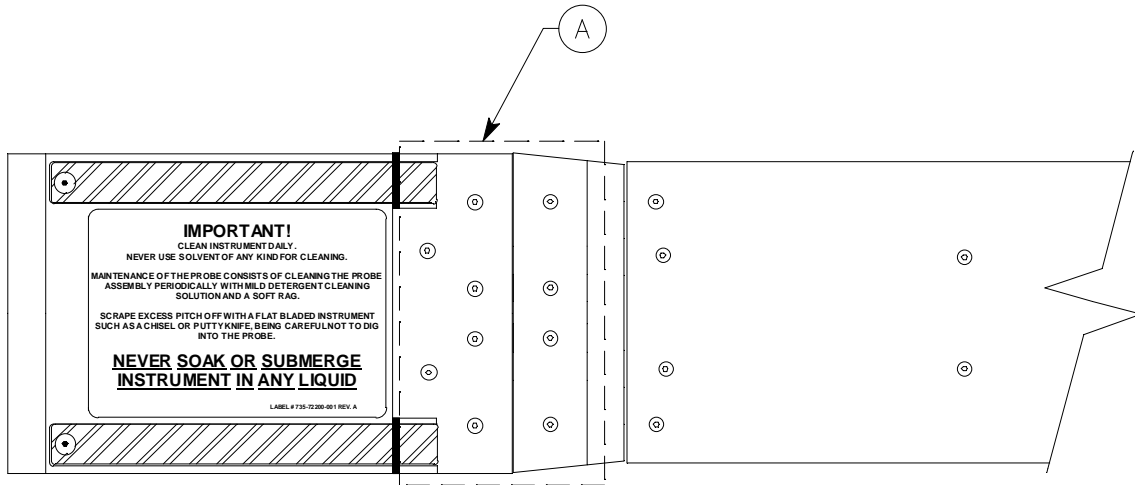

Symbol	Description
A	REMOVE HINGE SCREWS, AND RESEAT OR REPLACE HINGE. REPLACEMENT SCREWS: INCLUDED IN THE L722 PARTS KIT (#880-72202-001).

STORAGE

The stack probe should be stored in a cool dry environment.

L722 OPERATION

To connect a probe to the L612, remove the dust plug from the beige-colored port labeled “PROBE” on the meter and plug the connecting cable into this port.

With the probe connected to the L612 and the meter ON, insert the probe into the sticker space between the layers of boards in a stack of lumber. The springs press the end-mounted sensor flat against the wood. The actual sensing area of the probe is located in the end of the probe assembly on the opposite side of the springs. Be sure to insert and remove the probe straight in and straight out of the stack of lumber to avoid damage to the L722 springs and hinge.

When the probe is connected to the meter, the internal hand-meter sensor is bypassed and the probe will be the source of the readings. The backlight will also be turned on automatically for easier viewing in the dark kiln environment.

MAINTAINING ACCURACY OF MOISTURE CONTENT READINGS

The purpose of this section is to provide proper moisture content measurement techniques during kiln drying operations. The major factor of preserving consistent readings is to control the many variables that are present when moisture content (MC) values are measured. The control of these variables will be identified and addressed in the following paragraphs.

Taking L722 Stack Probe Measurements – The probe should be checked for proper calibration prior to use. This can be accomplished by verifying the stack probe on the calibration block. The L612 meter should be checked for general operation and battery condition. Ensure the L612 meter has been selected for the appropriate wood species being measured. Verify a good connection with the coil cord at the meter by making sure the moisture content value doesn't drift while wiggling the cable.

Consistent use of the stack probe will maintain the integrity of MC readings. Ensure the sensor plate area is completely covered by the lumber being measured. Take several measurements with the probe oriented along the length of the board, measure close to the “stickers” as wood surfaces will be more uniform at these locations.

Don't pull down on the probe handle because hinge damage may occur.

The kiln drying operations procedure should spell out the specific number of measurements to take, at what depth in the stack to measure, and when to measure them in the drying cycle. In order to maintain consistency, take readings in the same locations in the stack, and at the same times in the drying cycle from

one kiln charge to the next. You should take enough readings to be statistically significant. The more readings you take, the more accurate your “average” will be.

When taking measurements using a stack probe, you will be measuring the selected locations in the stack as stated in your kiln drying operations procedure. This will be the average moisture content of the scan area being measured directly under the sensor plate.

Keep in mind that the scan area of the L722 stack probe is 2.5” square (6.35cm) by 1” deep (2.54cm). This varies greatly from an in-line system, which has a much wider scan area (up to 12” square, 30.5cm), and deeper penetration. This will cause a larger area to be “averaged” with an in-line system.

The L722 stack probe readings will read excessively high when measuring severely knotted lumber due to higher density. Readings will be best when measured on a clear, flat area on the wide face of the lumber that is free of defects. If there is noticeable surface moisture, try not to measure at that spot until the moisture dissipates, or skip the area completely. As the moisture disperses, the effect will be minimized.

Kiln Drying, Moisture Gradients, and Temperature – Warm lumber tends to lose moisture after it is removed from the kiln and it continues to dry. It can also absorb moisture from the air in humid conditions during storage prior to planing. The moisture content of kiln-dried lumber is typically higher in the center core and dryer towards the ends and outer surfaces. Planing the dryer top and bottom sections of a board will cause the MC value to be higher. Because it is difficult to control all of these elements, it is best to try to maintain consistency in storage, and apply a correction factor as discussed in the paragraph below.

Frozen lumber can affect the MC readings. Wagner Electronics has found that if frozen lumber has a moisture content value lower than 15%, the readings are accurate. If the MC is higher than 15%, the actual reading obtained may be lower than the true value.

In a good measurement process consistency, repeatability, and correlation are the key factors. The goal is a better FINAL lumber product that meets your moisture content and grade goals. The closer your final product is to your target MC, the more cost efficient your drying process will be.

Here are some questions to ask yourself: Are all of your personnel taking the same number of readings? Are the readings being taken at the same time in the kiln dry schedule? Has my meter calibration been recently verified? Are the readings being taken at the same location in the same packs every time? This is the key to repeatability!

Applying Correction Factors - Due to variances beyond the control of the user, the MC values obtained from kiln dried lumber as read from the L612/L722 combination will likely not be exactly the same as read by an in-line system. An effective method to compensate for this is to establish a correction factor based on the nominal readings obtained in the kiln and the desired (target) MC reading as seen at the console. **You should be looking for a correlation between the stack probe readings and the in-line readings.**

Example: I measured packs 3, 7, 10 and 12 of 2x4 Douglas Fir in Kiln #1 by taking 50 readings in each pack after 20 hours of drying. I obtained a hot check average of 18%. I know the MC of this lumber going through the planer 3 days from now will have a 16.5% average.

Use the stack probe MC as a reference and adjust your correction factor as necessary to obtain the desired target MC at the in-line console. Compile data from previous kiln cycles to fine-tune your correction factor.

Consistency is the key! If your process changes, consider the impact to your correction factor, but do everything possible to control the variables. Don't complicate the variables by measuring one way this time and another way the next.

If your consistent correction factor suddenly stops working ask yourself: What has changed? Were the hot check readings taken the same way? Did the lumber have more MC variability going into the kiln? Did the meter recently get calibrated? Did the pack coming out of the kiln go through the planer sooner or later than usual?

Temperature can also have a small effect on the readings. We now know that high lumber temperatures can cause the MC reading to increase by 2-3%. These variances are far smaller than would be seen with a resistive pin meter. Some of this temperature related measurement error could be attributed to the warm lumber losing moisture as it cools.

Try to measure the lumber at approximately the same temperature from one cycle to the next to maintain the best consistency in your readings. If possible, let the wood cool for a couple of hours prior to measurement. The temperature effect is small, and correlation is the real goal, but more accuracy can be obtained by letting the temperature stabilize.

REPAIR SERVICE

In the event of damage or failure, the probe head can be removed from the extrusion. Open the handle and release the extrusion cable from the modular plug (see Figure 1). Remove the two hinge dock screws (see Figure 2). Gently pull the probe head and its attached cable from the extrusion.

Contact Wagner Electronics to obtain an RMA number & arrange for repair service:

Wagner Electronic Products, Inc.
326 Pine Grove Road
Rogue River, Oregon 97537
(541) 582-0541

You have the option of sending in your entire Stack Probe or the Stack Probe Head. Your equipment will be repaired, calibrated, and returned promptly.

If you would like to expedite the probe repair, a replacement probe head can be ordered and shipped to you directly by Wagner (Part# 860-72201-001 (long) or 860-72201-002 (short)).

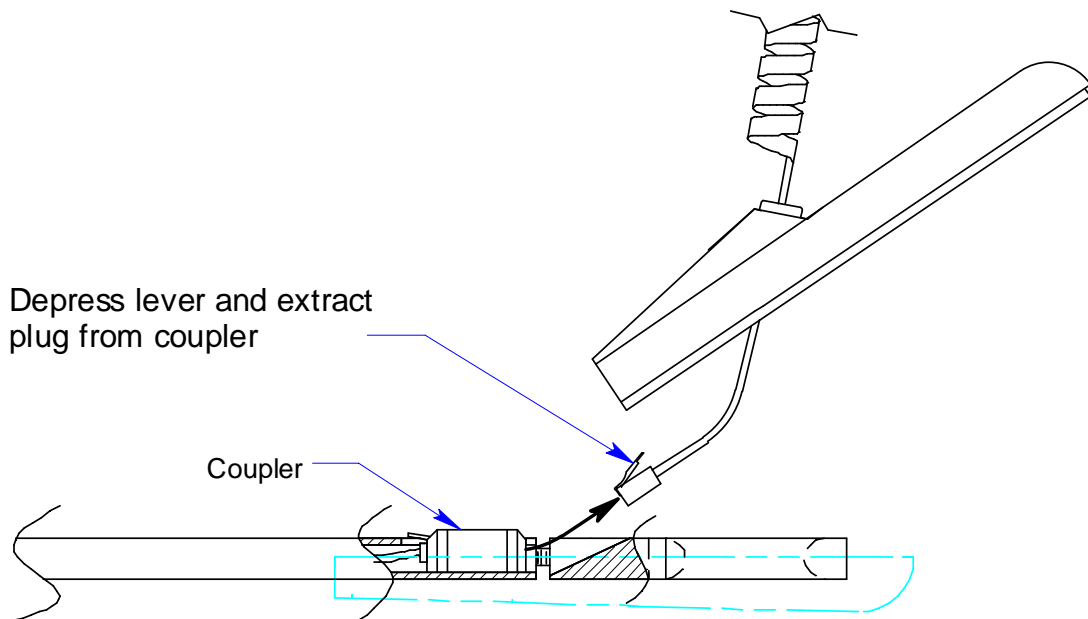

Figure 1

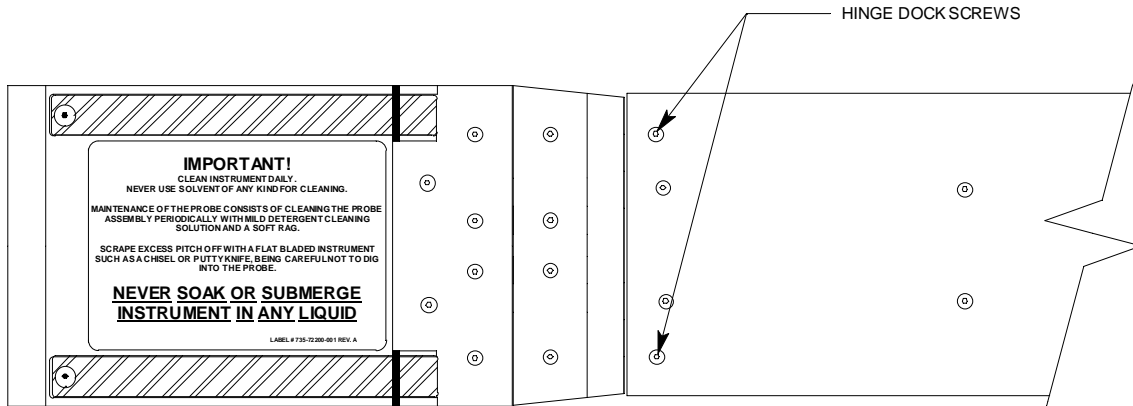

Figure 2

REPLACEMENT PARTS

Several parts can be ordered for the L722 using the part numbers as follows:

L712/L722 External Coil Cord	#830-71201-001
Probe Head, Long	#860-72202-001
Probe Head, Short	#860-72202-002
L722 Parts Kit	#880-72202-001
(L722 Parts Kit Includes: 4 Springs, 1 hinge, 2 probe end screws, 5 hinge screws & 2 Hex L-Keys).	

COIL CORD REPLACEMENT

If the coil cord becomes damaged, it can be replaced as described below:

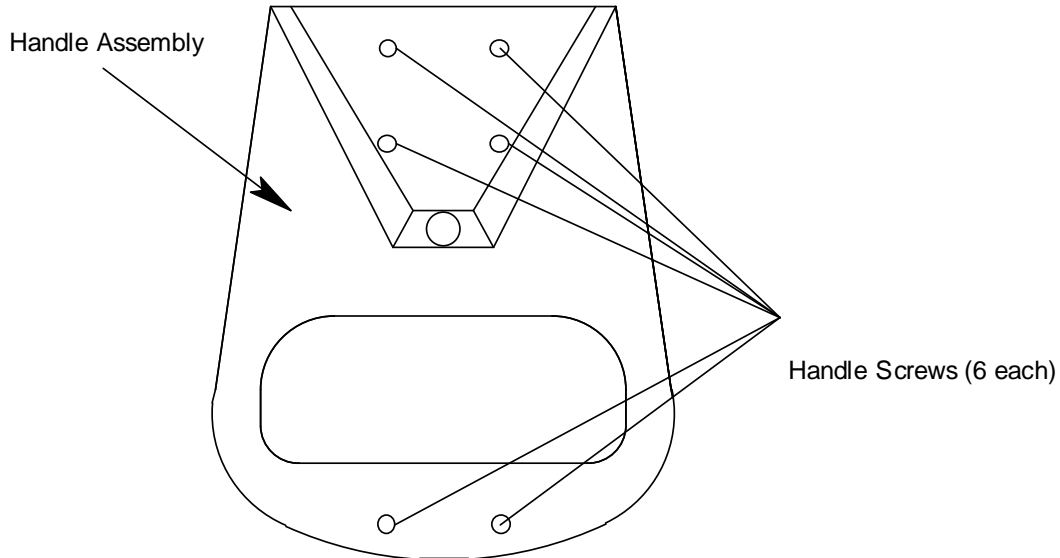

Step 1: Lay the L722 Stack Probe on a flat work space with the coil cord facing upward. Remove the 6 screws fastening the handle half-shells together. Separate the two halves of the handle.

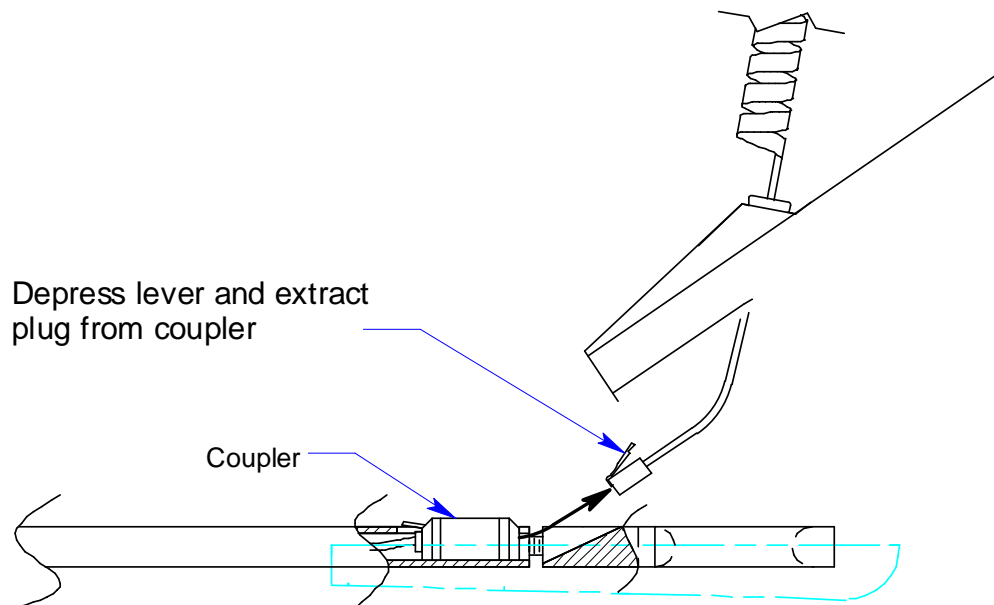

Step 2: Disconnect the old cord from the coupler.

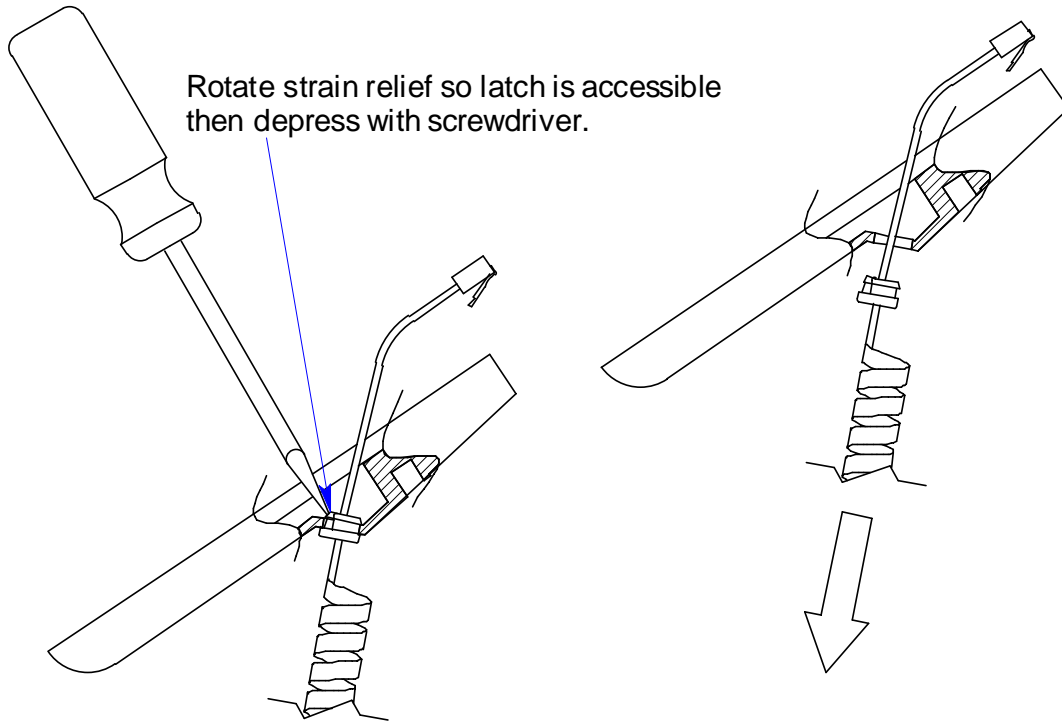

Step 3: Remove the old cord from the handle half-shell

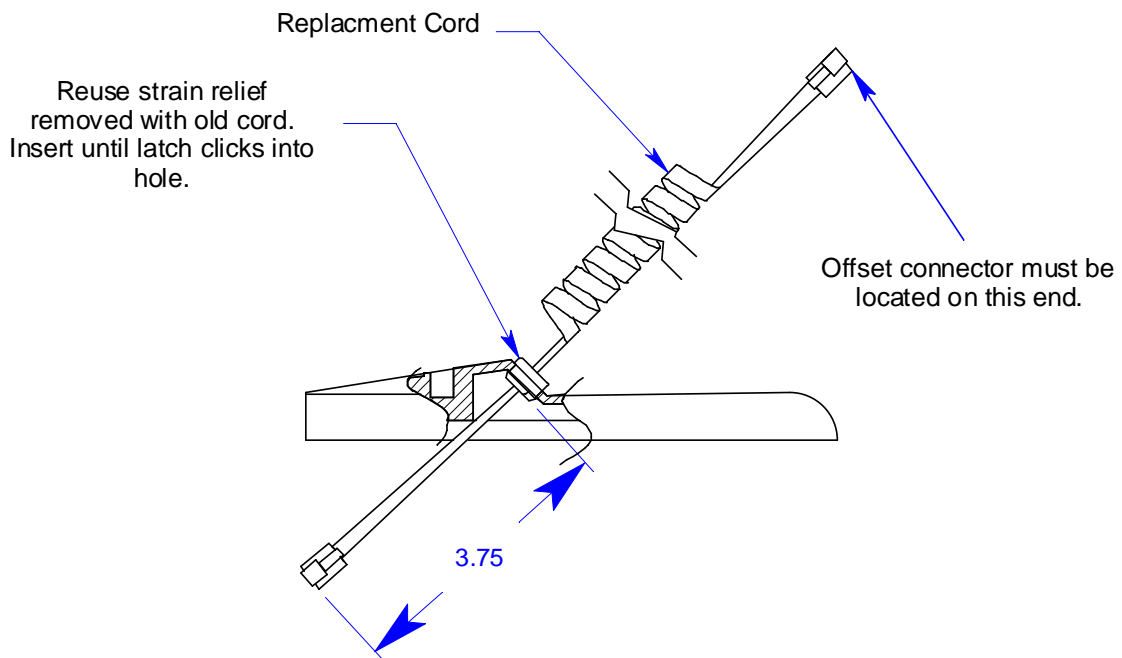

Step 4: Install Replacement Cord

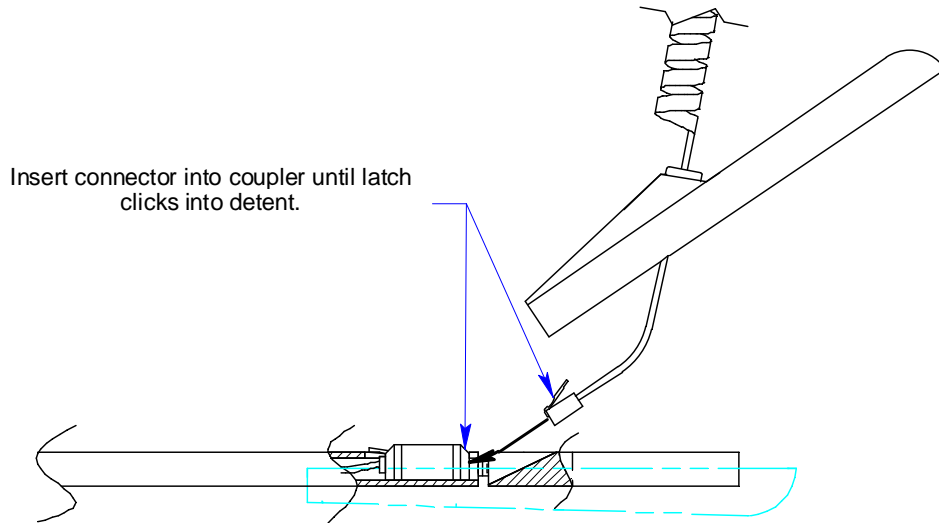

Step 5: Connect Replacement Cord to Coupler

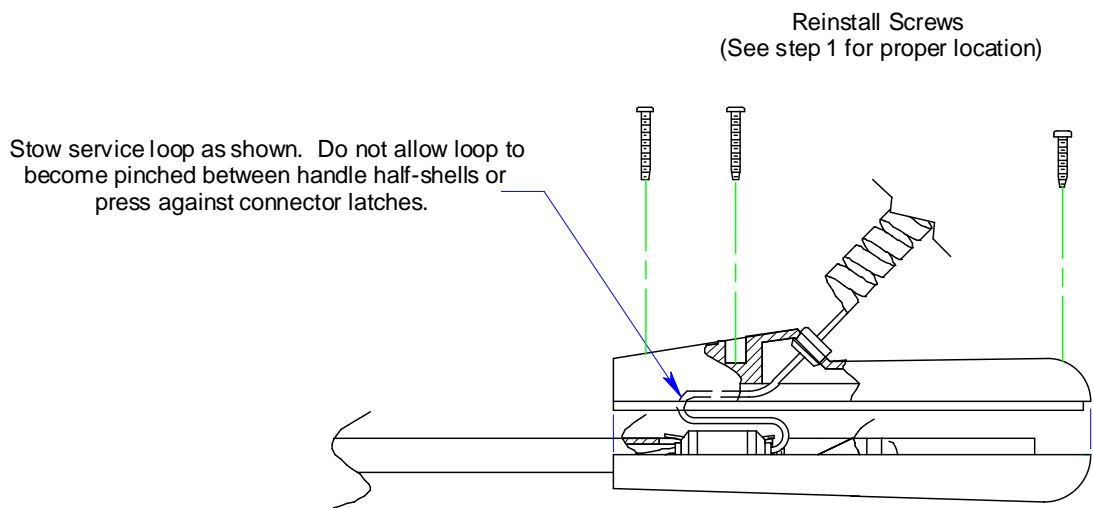

Step 6: Stow Service Loop and Reassemble Handle

Be sure to re-install probe head in reverse order.

WARRANTY

Wagner Electronic Products, Inc. warrants this product against defects in material and workmanship for one (1) year from the date of purchase, subject to the following terms and conditions:

Wagner's liability under this warranty shall be limited, at Wagner's option, to the repair or replacement of this product or any part thereof, which is demonstrated to be defective. To exercise this warranty, the customer must phone, fax, or e-mail Wagner's Technical Service Department for an RMA (Return Materials Authorization) number and factory instructions for shipment. This limited warranty does not apply if accident, negligent handling, misuse, alteration, damage during shipment, or improper service have damaged the product. Wagner Electronic Products, Inc. shall in no event be liable for any breach of warranty or defect in this product, which exceeds the amount of the purchase price of the product. Wagner Electronic Products, Inc. shall not be liable for incidental or consequential damages for the breach of any express or implied warranty with respect to this product or its calibration.

With proper care and maintenance, as recommended in the manual, the meter should stay in calibration; however, because Wagner Electronic Products, Inc. has no control over the manner in which the unit will be used, it makes no warranty that the meter will stay in calibration for any specific period of time. Wagner Electronic Products, Inc. recommends purchasing a calibration verification block or returning the unit to the factory for diagnostic checkup and recalibration on the anniversary date of purchase, each year the meter is in service.

This warranty is in lieu of all other warranties whether oral or written, expressed or implied. Any implied warranties, including implied warranties of merchantability and fitness for a particular purpose, are excluded.

Agents and employees of Wagner Electronic Products, Inc. are not authorized to make modifications to this warranty or additional warranties binding on Wagner Electronic Products, Inc. Accordingly, additional statements, whether oral or written (except written statements from an officer of Wagner Electronic Products, Inc.) do not constitute warranties and should not be relied upon by the customer.

This warranty is personal to the customer purchasing the product from Wagner Electronic Products, Inc. and is not transferable.

WARNINGS

WARNING

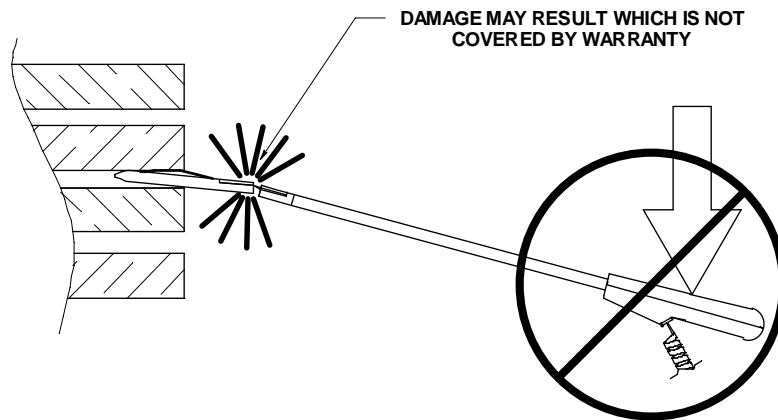

DO NOT APPLY VERTICAL PRESSURE TO HANDLE WHILE PROBE TIP IS STILL IN STACK.

CONDUCTIVE MATERIAL



THIS MATERIAL CAN CONDUCT HEAT AND ELECTRICITY